

Bath Planning Guidelines With Access Standards

1: Door/Entry

Recommended:

The clear opening of a doorway should be at least 32". This would require a minimum 2'-10" door.

If the existing structure precludes changing the opening then a minimum 2'-0" door is allowable.

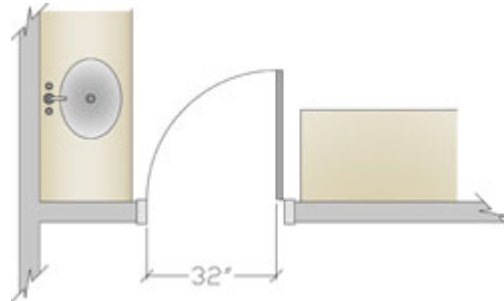

Code Requirement: State or local codes may apply.

Access Standard

Recommended:

The clear opening of a doorway should be at least 34". This would require a minimum 3'-0" door.

Code Reference:

Clear openings of doorways with swinging doors shall be measured between the face of door and stop, with the door open 90 degrees.(ANSI 404.2.3)

When a passage exceeds 24" in depth, the minimum clear opening increases to 36". (ANSI A 117.1 404)

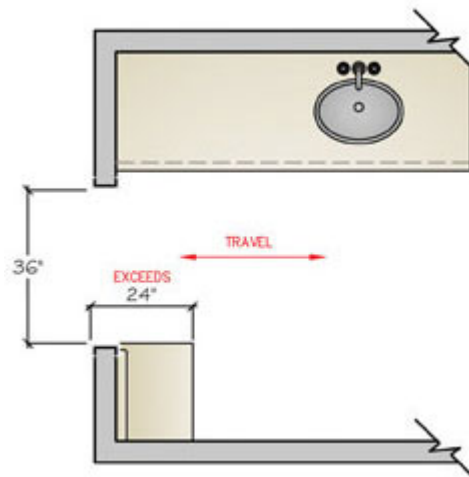
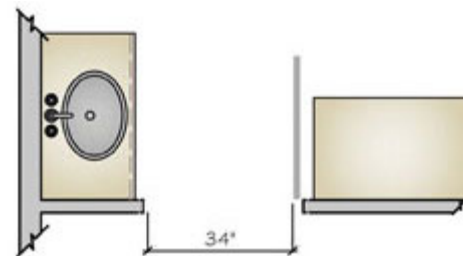

2: Door Interference

Recommended:

See Code Reference.

Code Requirement:

No entry or fixture doors should interfere with one another and/or the safe use of the fixtures or cabinets. (IRC P 2705.1.6)

Access standard

Recommended:

The door area should include clear floor space for maneuvering which varies according to the type of door and the direction of approach.

Code Reference:

For a standard hinged door or a swinging door, the minimum clearance on the pull side of the door should be the width of the door plus 18" by 60". (ANSI A 117.1 404.2.3.1)

The minimum clearance on the push side of the door should be the width of the door by 48". (ANSI A 117.1 404.2.3.1)

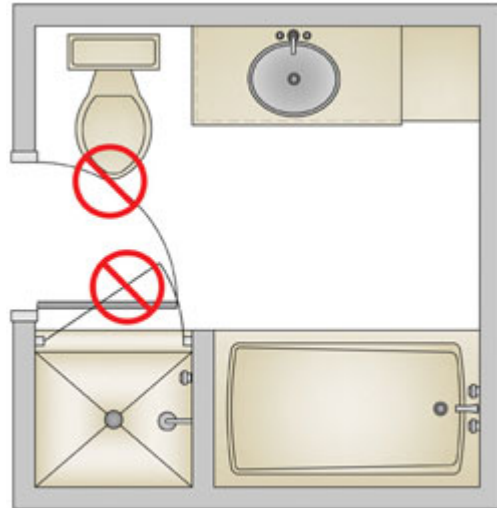

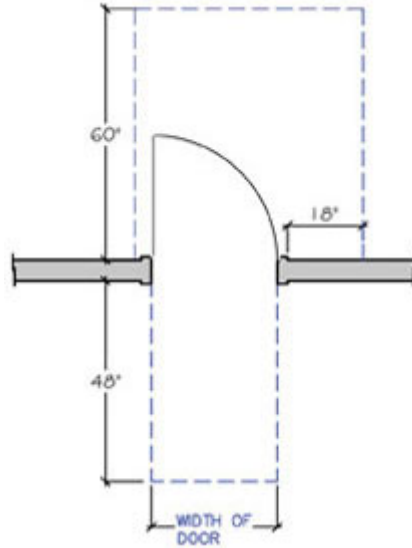

3: Ceiling Height

Recommended:

See Code Requirement

Code Requirement:

Bathrooms shall have a minimum floor to ceiling height of 80" over the fixture and at the front clearance area for fixtures.

A shower or tub equipped with a showerhead shall have a minimum floor to ceiling height of 80" above a minimum area 30" x 30" at the showerhead.

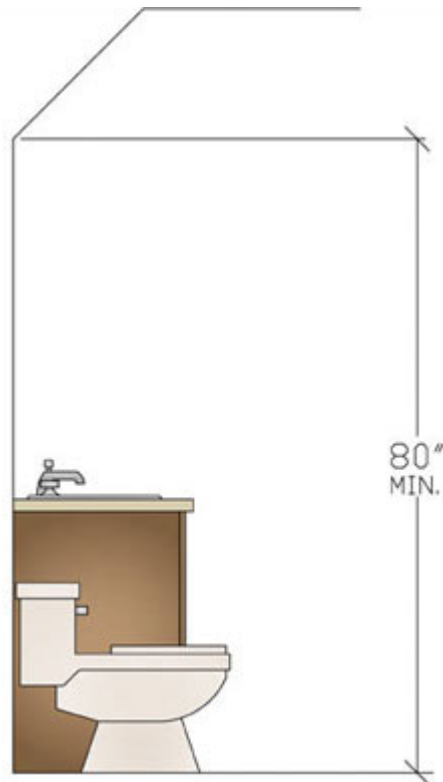

Access Standard

Recommended:

Bathroom guideline code requirement meets access standard.

4: Clear Space

Recommended:

Plan a clear floor space of at least 30” from the front edge of all fixtures (i.e., lavatory, toilet, bidet, tub and shower) to any opposite bath fixture, wall or obstacle.

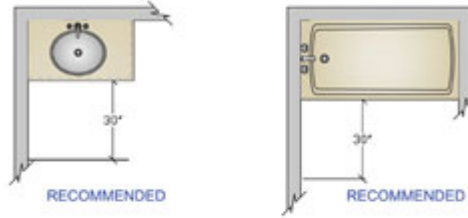

Code Requirement:

A minimum space of at least 21” must be planned in front of lavatory, toilet, bidet and tub. (IRC P 2705.1.5)

A minimum space of at least 24” must be planned in front of a shower entry. (IRC R 307.1)

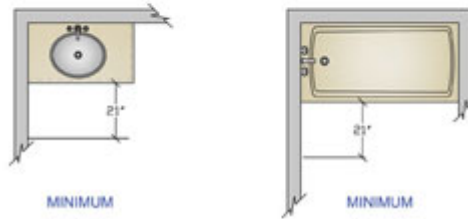

Access Standard

Recommended:

Plan a minimum clear floor space of 30” x 48” at each fixture, plus space for maneuvering including approach and turning for a person using a wheelchair.

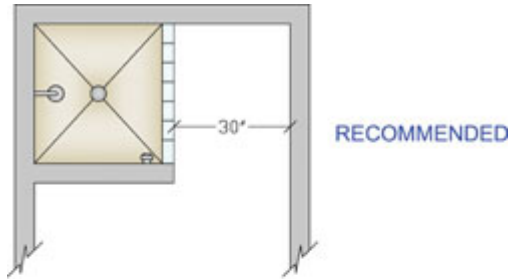

Plan a knee space at the lavatory or workspace to allow for a seated user. Recommended minimum size of a knee space is 36” wide x 27” high x 8” deep, increasing to 17” deep in the toe space, which extends 9” from the floor. Insulation for exposed pipes should be provided.

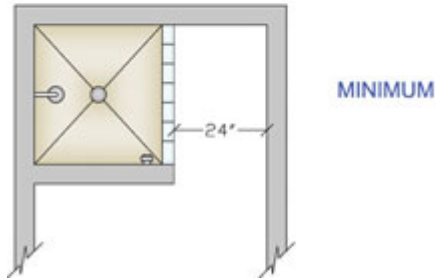

Consider the user’s method of transfer to the toilet to plan a clear space to fit the user’s needs.

Code Reference:

A clear floor space of at least 30” (762 mm) by 48” (1219 mm) should be provided at each fixture. (ANSI 305.3). Clear spaces can overlap.(ANSI 1002.11.2)

Include a wheelchair turning space with a diameter of at least 60” (1524

mm), which can include knee* and toe* clearances. (ANSI 304.3.1).

A wheelchair turning space could utilize a T-shaped space, which is a 60” square with two 12” wide x 24” deep areas removed from two corners of the square. This leaves a minimum 36” wide base and two 36” wide arms. T-shaped wheelchair turning spaces can include knee* and toe* clearances. (ANSI 304.3.2)

**Knee clearance must be a minimum 30” wide (36” to use as part of the T-turn) and maintain a 27” clear space under the cabinet, counter or sink for a depth of 8”. The next 11” of depth may slope down to a height of 9”, with a clear space of at least 17” extending beneath the element. (ANSI 306.3)*

**Toe clearance space under a cabinet or fixture is between the floor and 9” (229 mm) above the floor. Where toe clearance is required as part of a clear floor space, the toe clearance should extend 17” minimum beneath the element. (ANSI 306.2)*

Grooming

The clear floor space should be centered on the lavatory. (ANSI 1002.10.1)

Bathing and Showering

Clearance in front of bathtubs should extend the length of the bathtub and be at least 30” (762 mm) wide. (ANSI 607.2)

Code Reference:

Bathing and Showering

When a permanent seat is provided at the head of the bathtub, the clearance

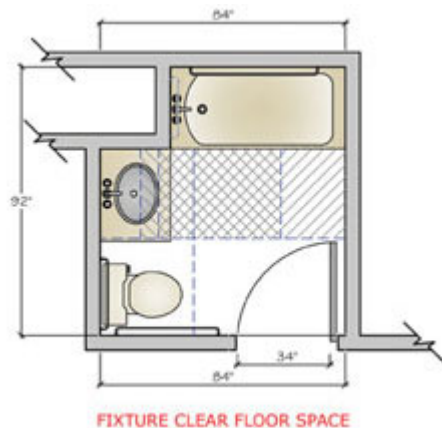
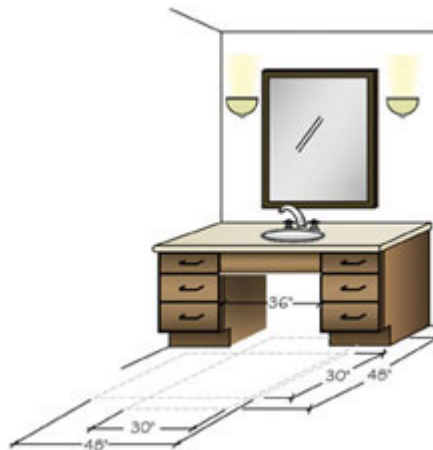
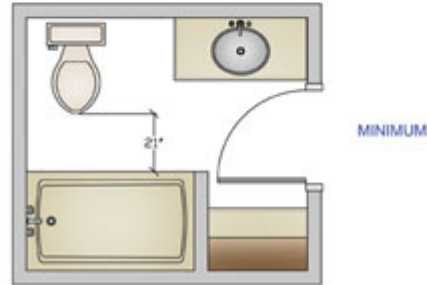
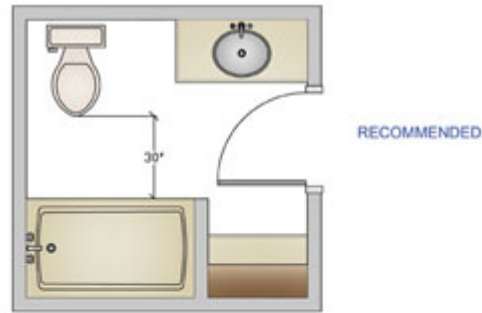

should extend a minimum of 12" (305 mm) beyond the wall at the head end of the bathtub. (ANSI 607.2)

The clearance in front of the transfer-type shower compartment should be at least 48" (1219 mm) long measured from the control wall and 36" (914 mm) wide. (ANSI 608.2)

The clearance in front of a roll-in-type shower compartment should be at least 60" (1524 mm) long next to the open face of the shower compartment and 30" (762 mm) wide. (ANSI 608.2)

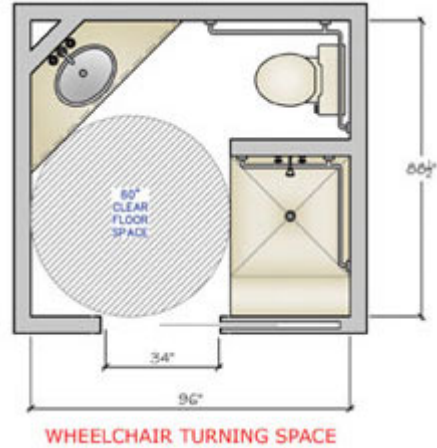

Toileting

When both a parallel and a forward approach to the toilet are provided, the clearance should be at least 56" (1422 mm) measured perpendicular from the rear wall, and 60" (1524 mm) measured perpendicular from the sidewall. No other fixture or obstruction should be within the clearance area. (ANSI 604.3.1, 1002.11.5.2.3)

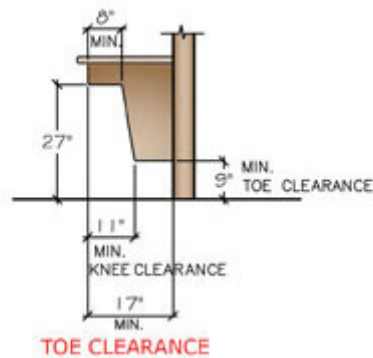
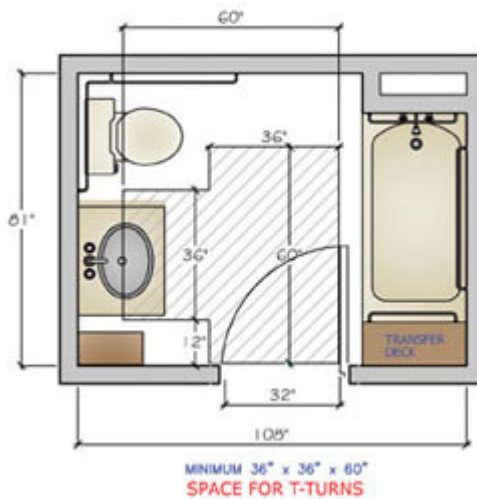

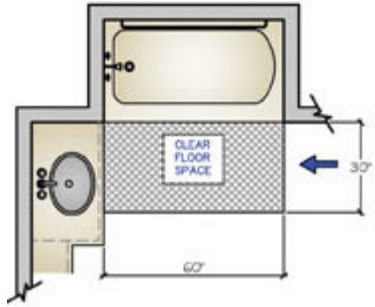

PARALLEL APPROACH

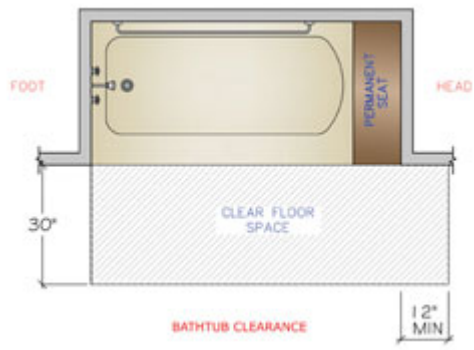

BATHTUB CLEARANCE

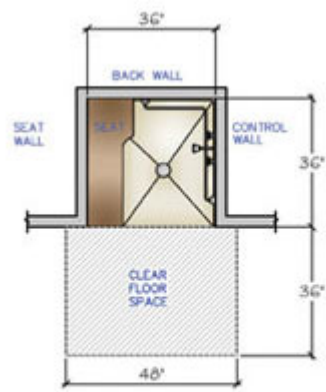

TRANSFER SHOWER

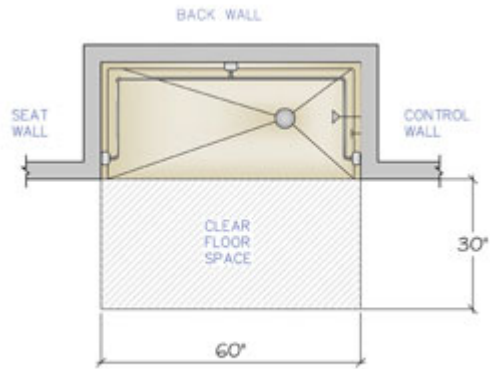

ROLL-IN SHOWER

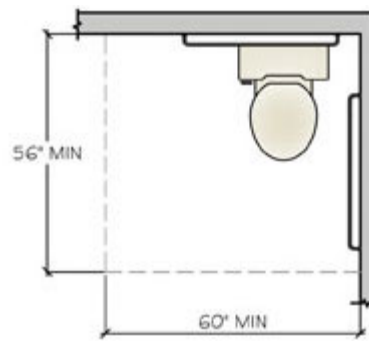

TOILET APPROACH

5: Lavatory Placement

Recommended:

The distance from the centerline of the lavatory to the sidewall/tall obstacle should be at least 20".

Code Requirement:

The minimum distance from the centerline of the lavatory to a wall is 15". (IPC 405.3.1)

The minimum distance between a wall and the edge of a freestanding or wall-hung lavatory is 4". (IRC R 307.1)

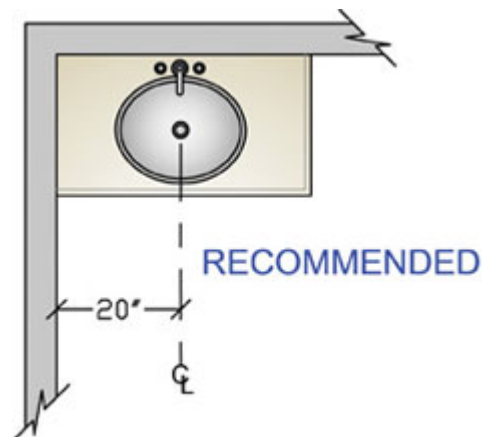

Access Standard

Recommended:

Bathroom guideline recommendation meets access standard.

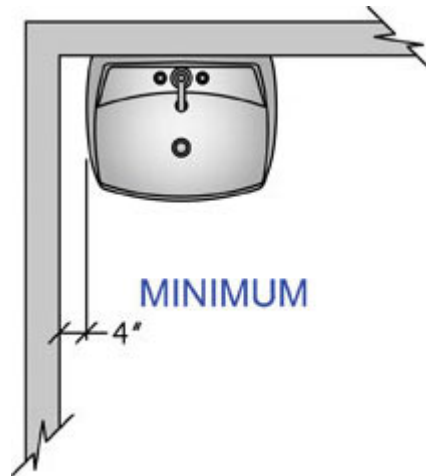
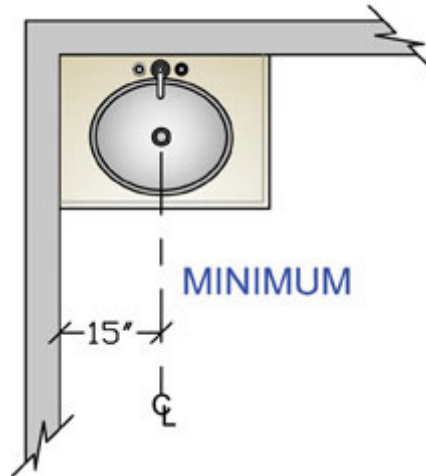

6: Double Lavatory Placement

Recommended:

The distance between the centerlines of two lavatories should be at least 36”.

Code Requirement:

The minimum distance between the centerlines of two lavatories should be at least 30”. (IPC 405.3.1)

The minimum distance between the edges of two freestanding or wall-hung lavatories is 4”. (IRC R 307.1)

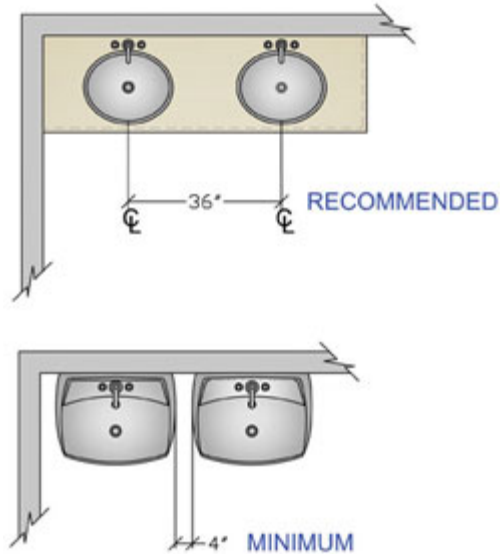

Access Standard

Recommended:

Bathroom guideline recommendation meets access standard.

7: Lavatory/Vanity Height

Recommended:

The height for a lavatory varies between 32” – 43” to fit the user.

Code Requirement: State or local codes may apply.



Access Standard

Recommended:

Lavatory controls should be within the user’s reach and operable with minimal effort.

Code Reference:

The front of the lavatory sink should be no more than 34” (864 mm) above the floor, measured to the higher of the fixture or counter surface. (ANSI 606.3)

Lavatory controls should be operable with one hand and not require tight grasping, pinching, or twisting of the wrist. (ANSI 309.4)

8: Counter

Recommended:

Specify clipped or round corners rather than sharp edges on all counters.

Code Requirements: State or local codes may apply.

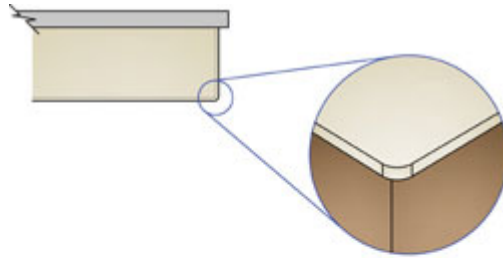

Access Standard

Recommended:

Bathroom guideline recommendation meets access standard.

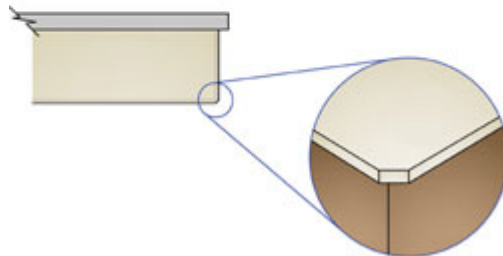

9: Shower Size

Recommended:

The interior shower size is at least 36" x 36".

Code Requirement:

The minimum interior shower size is 30" x 30" or 900 square inches, in which a disc of 30" in diameter must fit. (IRC P 2708.1, IPC 417.4)

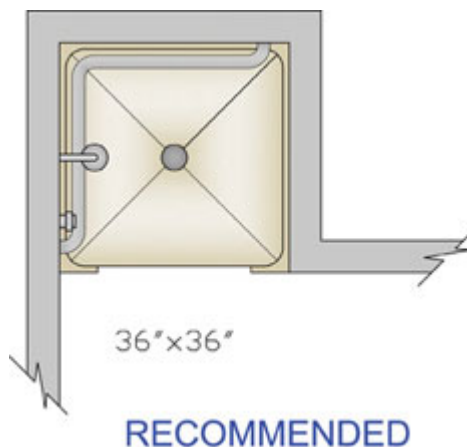

Access Standard

Recommended:

Plan either a transfer* or a roll-in** shower.

*A transfer shower, (36" x 36") provides

support to a standing person or one who can stand to transfer.

****A roll-in shower is a waterproof area large enough for a person in a wheelchair to remain in the chair to shower. A preferred minimum size for roll-in shower is 36" – 42" x 60".**

Recommended:

Roll-in shower entries: For a 60" deep shower, a 32" wide entry is adequate. For a 42" deep shower, the entry must be at least 36" wide to allow for turning space.

Code Reference:

Transfer-type shower compartments should have an inside finished dimension of 36" (914 mm) x 36" (914 mm), and have a minimum of 36" (914 mm) wide entry on the face of the shower compartment. A seat must be provided within the 36" x 36" area. (ANSI 608)

Roll-in-type shower compartments should have a minimum inside finished dimension of at least 30" (762 mm) wide by 60" (1524 mm) deep, and have a minimum of a 60" (1524 mm) wide entry on the face of the shower compartment. (ANSI 608.2.2)

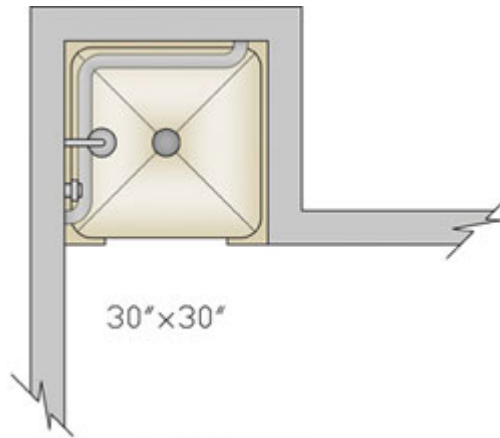

MINIMUM

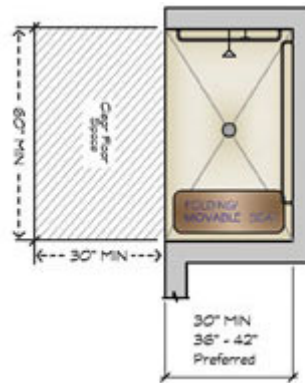

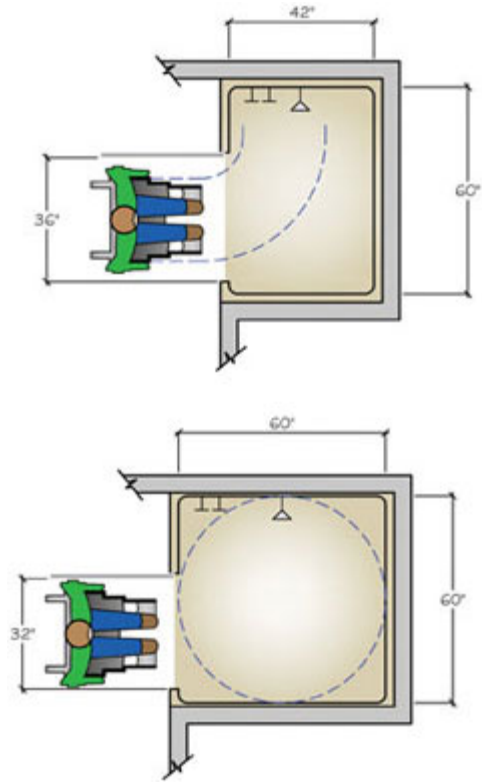

10: Tub/Shower Controls

Recommended:

1. The shower controls should be accessible from both inside and outside the shower spray and be located between 38" – 48" above the floor depending on user's height.
2. The tub controls should be accessible from both inside and outside the tub and be located between the rim of the bathtub and 33" above the floor.

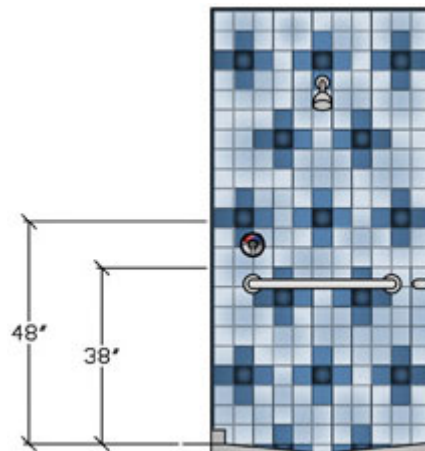

Code Requirement:

State or local codes may apply.

Access Standard

Recommended: Controls should be offset towards the room and easy to grasp, as with lever or loop handles (a and b).

Hot and cold should be identified with red and blue indicators.

Provide a handheld spray at a height accessible to the user (b).

Code Reference:

Tub/shower controls should be operable with one hand and not require tight grasping. (ANSI 309.4)

Controls should be on an end wall of the bathtub, between the rim and grab bar, and between the open side of the bathtub and the mid-point of the width of the tub. (ANSI 607.5) (a)

Controls in roll-in showers should be above the grab bar, but no higher than 48" (1219 mm) above the shower floor. In transfer type shower compartments, controls, faucets, and the shower unit should be on the sidewall opposite the seat, between 38" (965 mm) and 48" (1219 mm) above the shower floor. (ANSI 608.5) (b)

A handheld spray unit should be provided with a hose at least 59" (1499 mm) long that can be used as a fixed showerhead and as a handheld shower. In transfer type showers, the controls and shower unit should be on the control wall within 15" (381 mm) of the centerline of the seat (c). In roll-in type showers, shower spray units mounted on the back wall should be no more than 27" from the sidewall. If an adjustable height showerhead mounted on a vertical bar is used, the bar should not obstruct the use

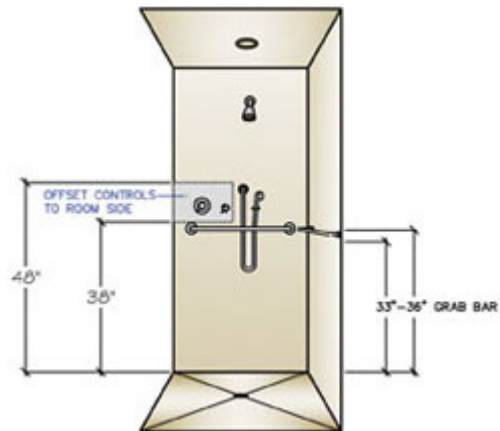
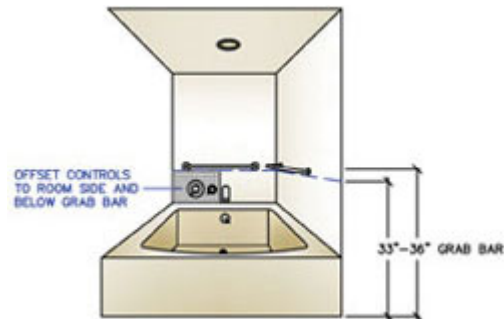
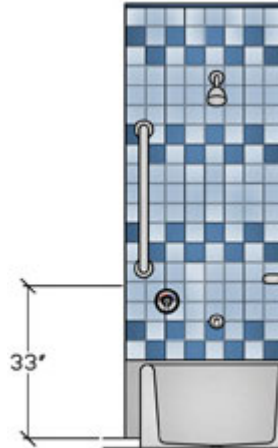

of the grab bars. (ANSI 608.6)

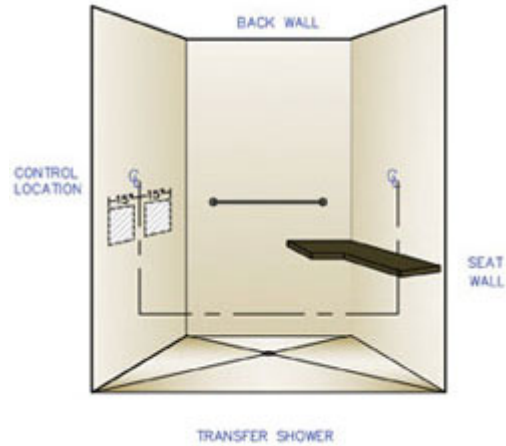

11: Shower/Tub Control Valves

Recommended: See below

Code Requirement:

Shower and tub/shower control valves must be one of the following:

- pressure balanced
- thermostatic mixing
- combination pressure balance/thermostatic mixing valve types (IRC P2708.3)



Access Standard

Recommended:

Bathroom guideline code requirement meets access standard.

12: Shower/Tub Seat

Recommended:

Plan a seat within the shower that is 17” – 19” above the shower floor and 15” deep.

Code Requirement:

Shower seat must not infringe on the minimum interior size of the shower (900 square inches). (IRC P 2708.1)

Access Standard

Recommended: Plan a seat in the shower and/or bathtub to fit the parameters of the space and the needs of the user.

Code Reference:

A removable in-tub seat should be at least 15” (381mm) – 16” (406 mm) deep and capable of secure placement. (ANSI 610.2)

A permanent tub seat should be at least 15” (381 mm) deep and positioned at the head end of the bathtub. The top of the seat should be between 17” (432 mm) and 19” (483 mm) above the bathroom floor. (ANSI 610.2)

Where a seat is provided in a roll-in shower, it should be a folding type and on the wall adjacent to the controls. The top of the seat should be between 17” (432 mm) and 19” (483 mm) above the bathroom floor.

In a transfer-type shower, the seat should be a folding type and extend from the back wall to a point within 3” (76 mm) of the shower entry. (ANSI 610.3)

The materials and installation of the shower and/or bathtub seat must support a minimum of 250 pounds of pressure. (ANSI 610.4)

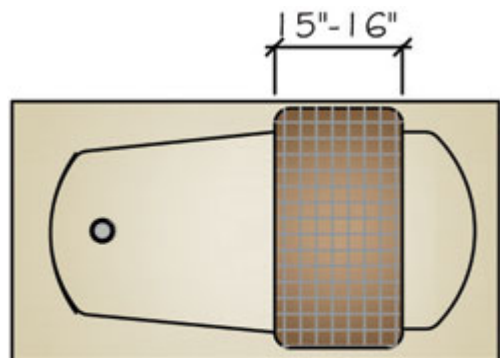
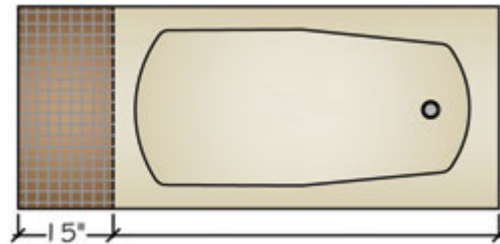
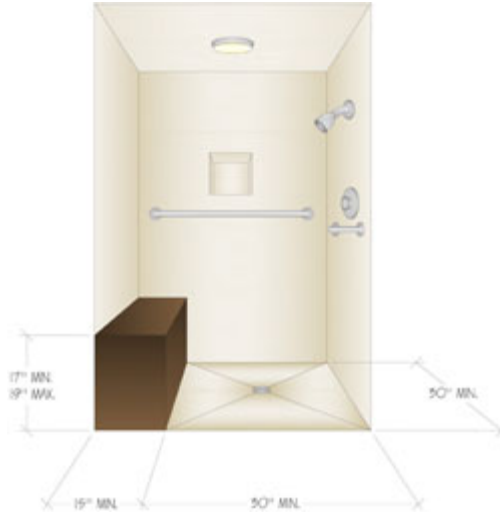

(a) REMOVEABLE IN-TUB SEAT

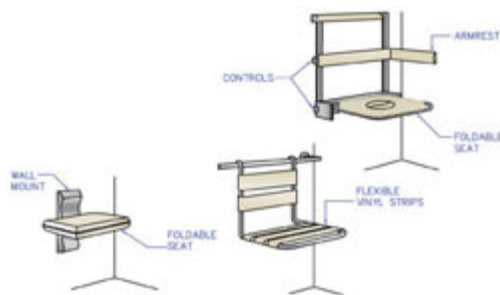

13: Tub/Shower Surround

Recommended:

The wall area above a tub or shower pan should be covered in a waterproof material extending at least 3” above the showerhead rough in.

Code Requirement:

The wall area above a tub or shower pan must be covered in a waterproof material to a height of not less than 72” above the finished floor. (IPC 417.4.1, IRC R 307.2)

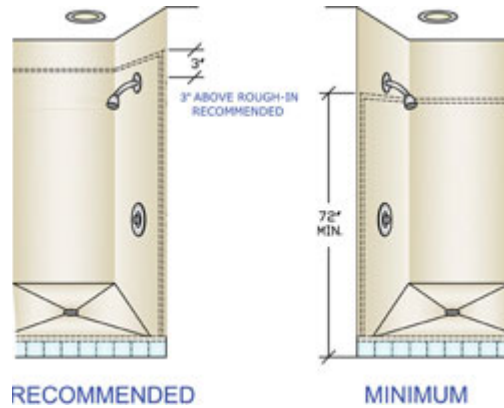

Access Standard

Recommended:

Bathroom guideline recommendation meets access standard.

14: Grab Bars

Recommended:

Plan grab bars to facilitate access to and maneuvering within the tub and shower areas.

Tub and shower walls should be prepared (reinforced) at time of construction to allow for installation of grab bars to support a static load of 250 lbs.

Grab bars should be placed at least 33” – 36” above the floor.

Grab bars must be 1 1/4” to 2” in diameter and extend 1 1/2” from the wall.

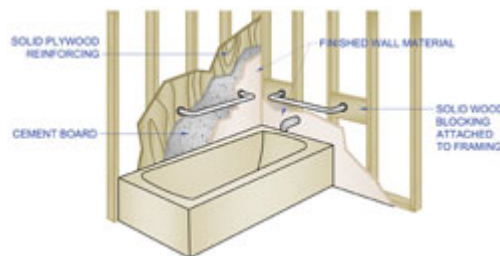

Access Standard

Recommended: Walls throughout the bathroom should be prepared (reinforced) at time of construction to allow for installation of grab bars to support a minimum of 250 lbs. of pressure.

Grab bars should be placed according to the needs and height of the user, particularly near the tub/shower and the toilet.

Code Reference:

Grab bars should be installed at the tub, shower, and toilet according to the following:

Bathtubs with permanent seats: Two horizontal grab bars (a1) should be provided on the back wall, one between 33" (838 mm) and 36" (914 mm) above the floor and the other 9" above the rim of the bathtub (a2). Each grab bar should be no more than 15" (381 mm) from the head end wall or 12" (305 mm) from the foot end wall. A grab bar 24" (610 mm) long should be provided on the foot end wall at the front edge of the bathtub. (ANSI 607.4.1)

Bathtubs without permanent seats: Two horizontal grab bars should be provided on the back wall, one between 33" (838 mm) and 36" (914 mm) above the floor and the other 9" above the rim of the bathtub (a3). Each grab bar should be at least 24" (610 mm) long and no more than 24" (610 mm) from the head end wall or 12" (305 mm) from the foot end wall. A grab bar 24" (610 mm) long should be provided on the foot end wall at the front edge of the bathtub. A grab bar 12" (305 mm) long should be provided on the head end wall at the front edge of the bathtub (a4). (ANSI 607.4.2)

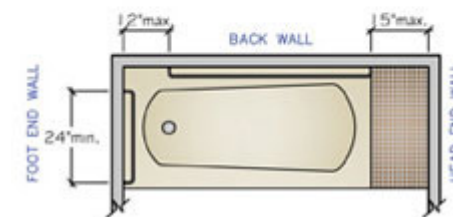
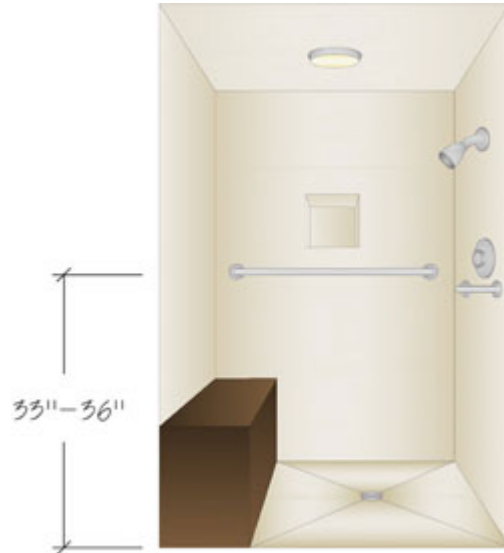
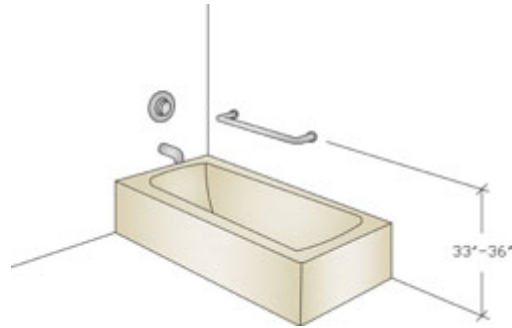

Transfer-type showers: Grab bars should be mounted in a horizontal position, between 33” and 36” above the floor, across the control wall and across the back wall to a point 18” from the control wall. (ANSI 608.3.1) (b)

Roll-in type shower: Grab bars should be mounted in a horizontal position, between 33” and 36” above the floor, on all three walls of the shower, but not behind a seat. Grab bars should be no more than 6” from each adjacent wall. (ANSI 608.3.2) (c1, c2 and c3)

Toilet: Grab bars should be provided on the rear wall and on the sidewall closest to the toilet. The sidewall grab bar should be at least 42” (1067 mm) long and located between 12” (305 mm) and 54” (1372 mm) from the rear wall. The rear grab bar should be at least 24” (610 mm) long, centered on the toilet. Where space permits, the bar should be at least 36” (914 mm) long, with the additional length provided on the transfer side of the toilet. (ANSI 604.5) (d1 and d2)

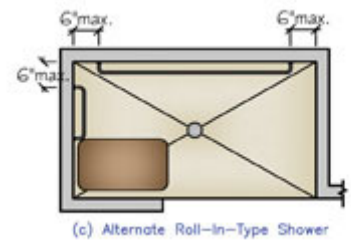
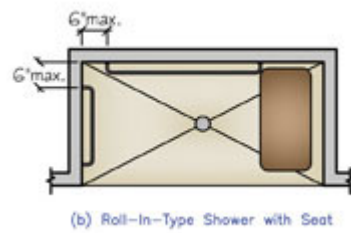
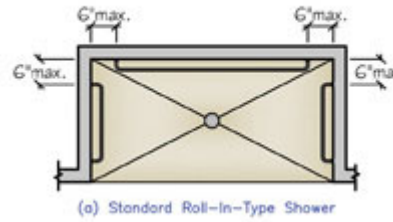
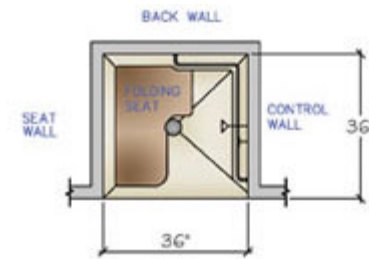
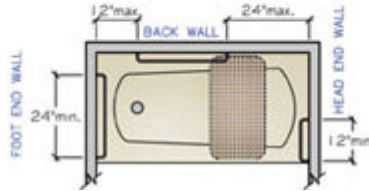
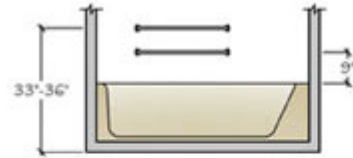

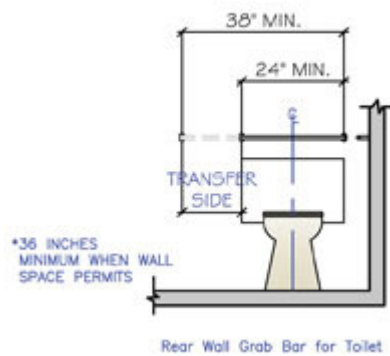
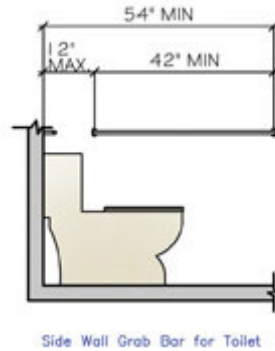

15: Glazing

Recommended: See Code Requirement

Code Requirement:

Glass used in tub or shower enclosures (i.e. tub or shower door) or partitions must be tempered or an approved equal and must be permanently marked as such. (IRC R 308.1)

If the tub or shower surround has glass windows or walls, the glazing must be tempered glass or approved equal when the bottom edge of glazing is less than 60" above any standing or walking surface. (IRC R 308.4.5)

Any glazing (i.e. windows or doors) whose bottom edge is less than 18" above the floor must be tempered glass or



approved equal. (IRC R 308.4.7.2)

Access Standard

Recommended:

Bathroom guideline code requirements meet access standard.

16: Tub/Shower Door

Recommended:

See Code Requirement

Code Requirement:

Hinged shower doors shall open outward. (IRC P 2708.1)

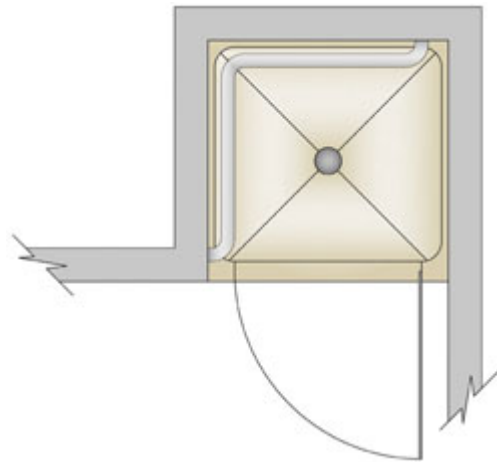

Access Standard

Recommended:

Minimize thresholds at the shower entry to no more than 1/2”.

Code Reference:

Shower compartment thresholds should be no more than 1/2” (13 mm) high. Changes in level of no more than 1/4” (6 mm) high are permitted, but changes in level between 1/4” (6 mm) high and 1/2” (13 mm) high should be beveled with a slope not steeper than 1:2. (ANSI 608.7.303)

17: Steps

Recommended:

Steps should not be placed outside a tub.

If steps are used a grab bar/handrail is mandatory.

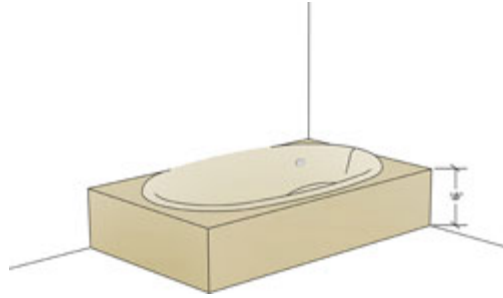

Access Standard

Recommended:

Bathroom guideline recommendation meets access standard

18: Flooring

Recommended:

Slip-resistant surfaces should be specified for the general bath flooring, shower floors, and tub/shower bottoms.

Code Requirement:

State or local codes may apply.

Access Standard

Recommended: Bathroom guideline recommendation meets access standard.

Code Reference:

Plan a slope for the bathtub or shower drain with a maximum slope of 1:48 pitch 1/4 inch per foot(ratio 1:48). (ANSI 403.3)



19: Equipment Access

Recommended:

See below

Code Requirement:

All equipment, including access panels, must be installed as per manufacturers' specifications. (IRC M 2720.1)

All manufacturers' instructions must be available for installers and inspectors and left for homeowners. (IRC P 1307.1)

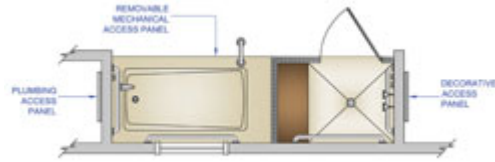

Access Standard

Recommended:

Bathroom guideline code requirement meets access standard.

20: Toilet/Bidet Placement

Recommended:

The distance from the centerline of toilet and/or bidet to any bath fixture, wall or other obstacle should be at least 18".

Code Requirement:

A minimum distance of 15" is required from the centerline of toilet and/or bidet to any bath fixture, wall or other obstacle. (IRC R 307.1, IRC P 2705.1.5, IPC 405.3.1)

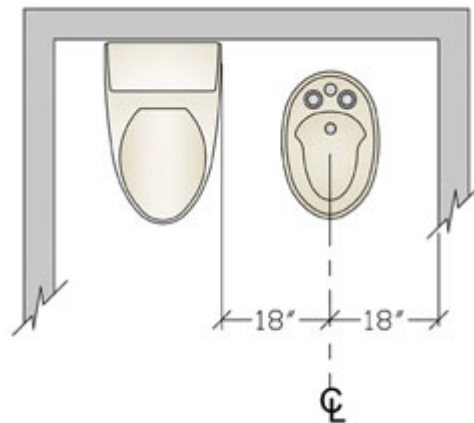

RECOMMENDED

Access Standard

Recommended:

The recommended toilet height is between 15" and 19" high.

Code Reference:

The toilet should be centered 16" to 18" from a side wall. (ANSI 1002.11.5)

The toilet seat should be between 15" and 19" from the floor. (ANSI 1002.11.5.3)

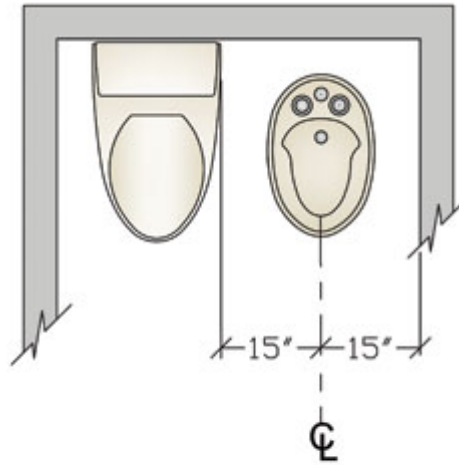

MINIMUM

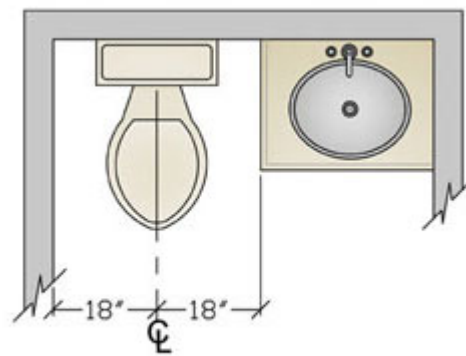

RECOMMENDED

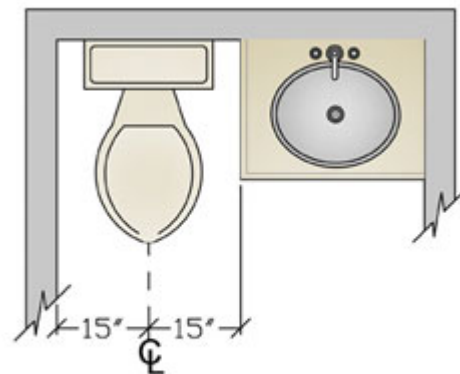

MINIMUM

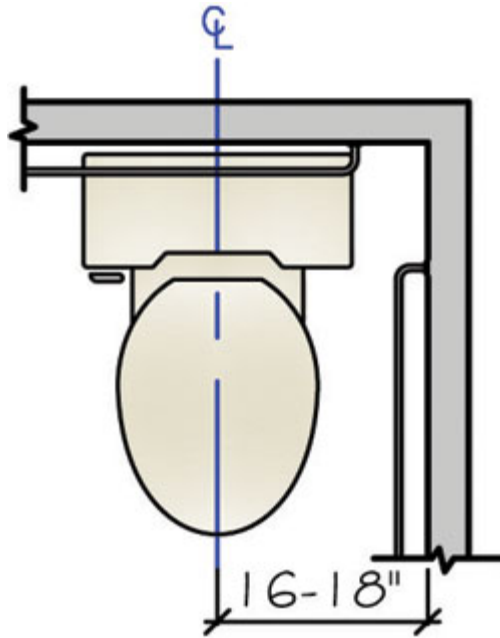

21: Toilet Compartment

Recommended:

The size for a separate toilet compartment should be at least 36" x 66" with a swing-out or pocket door.

Code Requirement:

The minimum size for a separate toilet compartment is 30" x 60". (IPC 405.3.1)

Access Standard

Recommended:

To maximize access, provide privacy in the toileting area without using a separate compartment.

Code Reference:

Wheelchair accessible compartments should be at least 60" (1524 mm) wide,

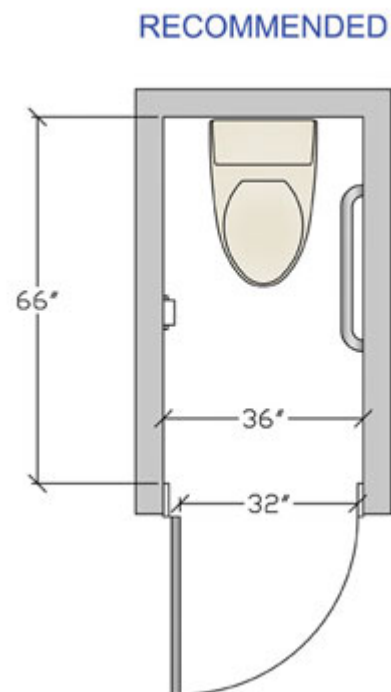

measured perpendicular to the sidewall, and 56" (1422 mm) deep for a wall hung toilet and at least 59" (1499 mm) deep for a floor-mounted toilet measured perpendicular to the rear wall. (ANSI 604.8.1.1)

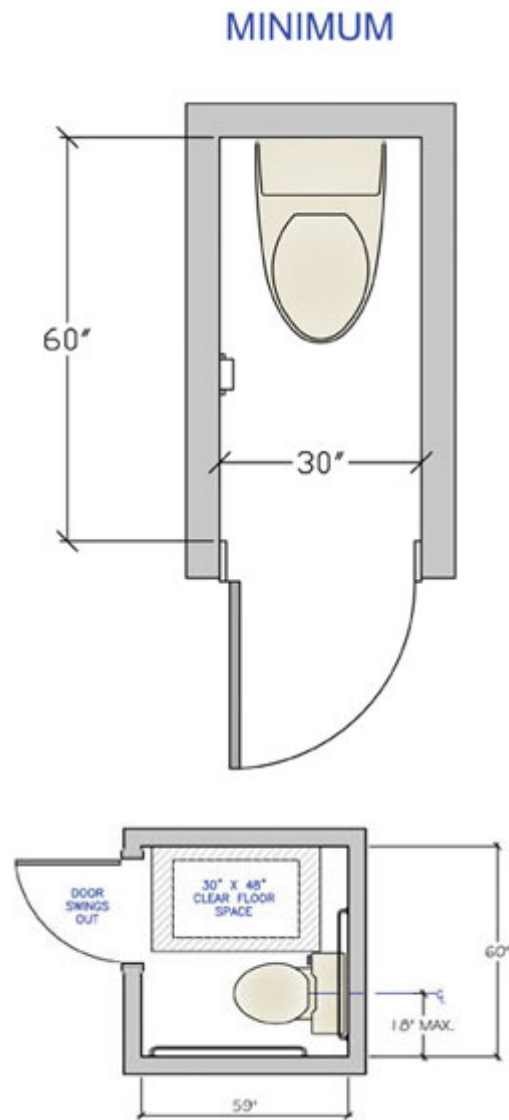

22: Storage

Recommended:

Provide adequate, accessible storage for toiletries, bath linens, grooming and general bathroom supplies at point of use.

Code Requirement:

State or local codes may apply.

Access Standard

Recommended:

Plan storage of frequently used items 15” to 48” above the floor.

Code Reference:

Where a forward or side reach is unobstructed, the high reach should be 48” maximum and the low reach should be 15” minimum above the floor. (ANSI 308.2.1, 308.3.1)

Where a forward or side reach is obstructed by a 20” – 25” deep counter, the high reach should be 44” maximum. (ANSI 308.2.2, 308.3.2)

Door/drawer pulls should be operable with one hand, require only a minimal amount of strength for operation, and should not require tight grasping. (ANSI 309.4)

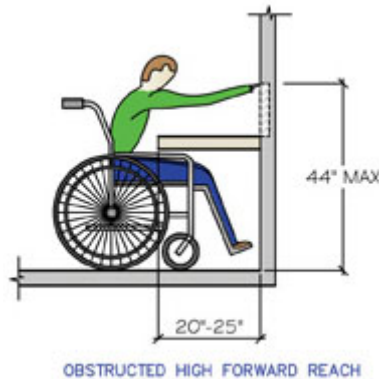
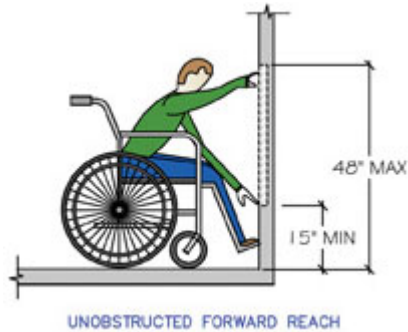

Recommended:

1. Place a mirror above or near the lavatory at a height that takes the user's eye height into consideration.
2. The toilet paper holder should be located 8" – 12" in front of the edge of the toilet bowl, centered at 26" above the floor.
3. Additional accessories, such as towel holders, soap dishes, etc., should be conveniently located near all bath fixtures.

Code Requirement:

State or local codes may apply.

Access Standard

Recommended:

1. Plan a full height mirror to provide reflection at eye level, regardless of the user's height or stature.
2. See code reference on toilet paper placement.
3. Accessories should be placed between 15" and 48" above the floor, and operable with a closed fist and with minimal effort.

Code Reference:

Mirrors above lavatories should have the bottom edge of the reflecting surface no more than 40" (1016 mm) above the floor. (ANSI 603.3) (a)

The toilet paper holder should be 7" – 9" in front of the toilet bowl and between 15" (381 mm) and 48" (1219 mm) above the floor. There should be a clearance of at least 1 1/2" (38 mm) below or 12" (305 mm) above the grab bar. (ANSI 604.7) (b)

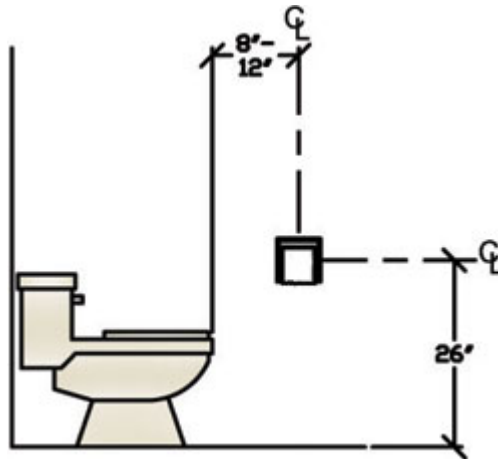

See Access Standard 22 for reach specifications.

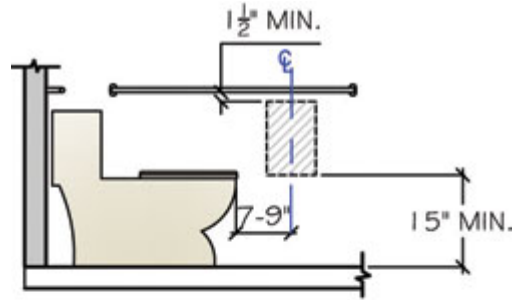

(a) BELOW GRAB BAR

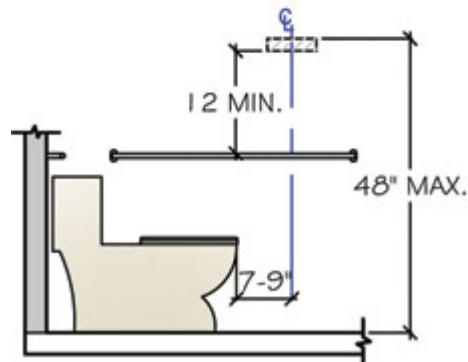

(b) ABOVE GRAB BAR

24: Electrical Receptacles

Recommended:

All GFCI receptacles should be located at electrical appliance points of use.

Code Requirement:

At least one GFCI protected receptacle must be installed within 36" of the outside edge of the lavatory. (IRC E 3801.6)

All receptacles must be protected by ground fault circuit interrupters (GFCI). (IRC 3802.1)

A receptacle shall not be installed within a shower or bathtub space. (IRC E 3902.11)



Access Standard

Recommended: Task lighting at the vanity should be beside the mirror and at eye level and with the lamp not visible to the eye.

Lighting controls should be between 15” and 48” above the floor and operable with a closed fist and with minimal effort.

Code Reference:

Operable parts should be operable with one hand and not require tight grasping, pitching, or twisting of the wrist. The force required to activate operable parts should be 5 pounds maximum. (ANSI A117.1 309.4)

See Access Standard 22 for specifications for reach range for controls.

26: Ventilation

Recommended:

Plan a mechanical exhaust system, vented to the outside, for each enclosed area.

Code Requirement:

Minimum ventilation for the bathroom is to be a window of at least 3 sq. ft. of which 50% is operable, or a mechanical ventilation system of at least 50 cubic feet per minute (cfm) ducted to the outside. (IRC R 303.3, IRC M 1506.3)

Access Standard

Recommended:

Ventilation controls should be placed 15” –

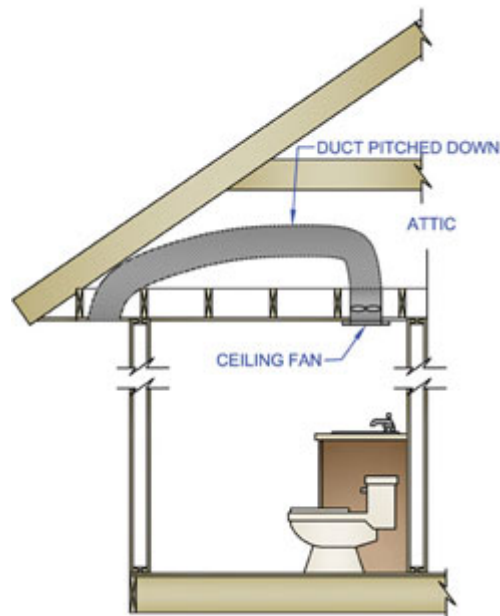

48" above the floor, operable with minimal effort, easy to read, and with minimal noise pollution.

Code Reference:

See Access Standard 25 for operable controls.

See Access Standard 22 for reach range for controls.

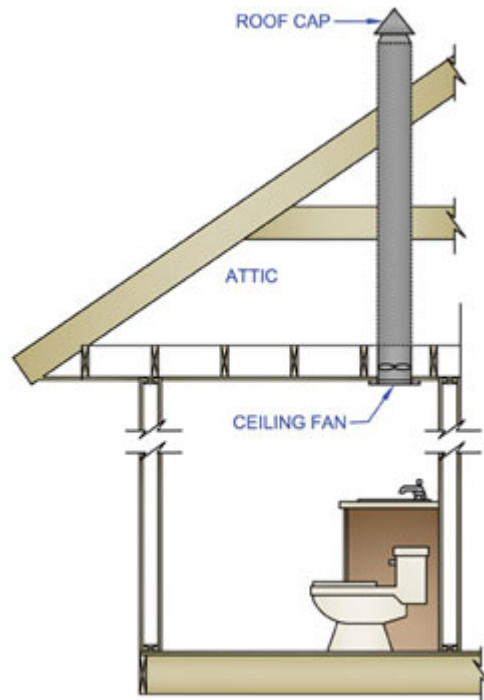

27: Heat

Recommended:

A supplemental heat source, i.e., heat lamp, toe kick heater, or floor heat should be considered.



Code Requirement:

All bathrooms should have an appropriate heat source to maintain a minimum room temperature of 68 degrees Fahrenheit (20 Celsius). (IRC R 303.8)

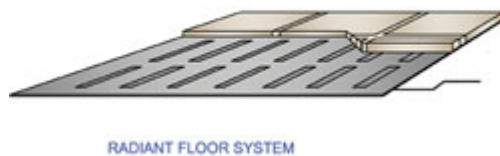

Access Standard

Recommended:

See Code Reference.

Code Reference:

See Access Standard 25 for operable controls.

Access Standard 22 for reach range for controls.

